

Hughes 9250 BGAN Mobile Satellite Terminal

HUGHES®



Broadband satellite
IP terminal and
WLAN access point



Imagine connecting at IP broadband rates of up to 464 Kbps transmit and receive while on the move—with a complete mobile communications package that includes an IP broadband satellite IP modem and tracking antenna. That's exactly what comes with the breakthrough Hughes 9250 mobile satellite terminal. Fully approved for operation on Inmarsat's global* BGAN satellite service, it means high-performance connectivity on the move for the most demanding environments.

Ideal for emergency responders, reporters, and mobile workers who need reliable, high-speed connectivity on the move.

Collaborate with staff back at headquarters using video, voice, and data simultaneously. Create a wireless hotspot for team members on the scene using the built-in WiFi Access Point. The Hughes 9250 is IP compatible and offers selectable, dedicated Quality of Service levels. And it's easy to install on any vehicle—the compact tracking antenna is packaged with a magnetic roof mount and a single cable connection.

The Hughes 9250 allows you to send and receive IP packet data via Ethernet and WLAN interfaces in a land-vehicular application. In parallel with the packet data services, the same terminal supports a circuit switched voice call or a 64kbps ISDN data call.

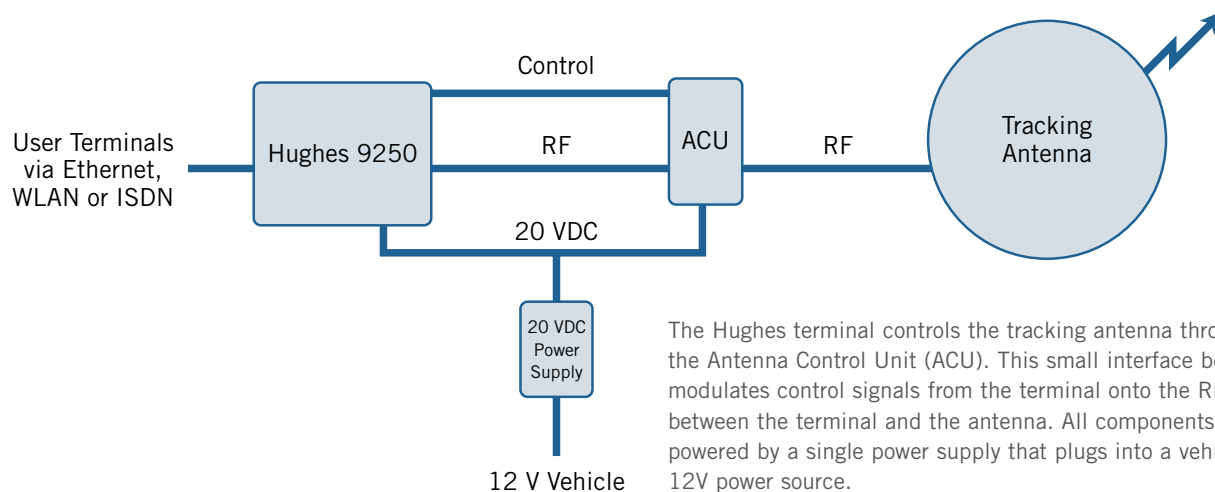

The Hughes terminal controls the tracking antenna through the Antenna Control Unit (ACU). This small interface box modulates control signals from the terminal onto the RF link between the terminal and the antenna. All components are powered by a single power supply that plugs into a vehicular 12V power source.

Features

Key features:

- Fully autonomous tracking antenna acquires and tracks the BGAN satellite signal while on the move
- Easy antenna installation (magnetic mount) on vehicle roof
- Includes antenna control unit and all cables and power supplies for vehicular installation
- Up to 464kbps shared data rate and 128kbps streaming IP data rate.**

Additional features:

- ISDN bearer capabilities: speech (4kbps), 3.1k audio (64kbps), ISDN data (64kbps)
- Allows simultaneous use of all interfaces (Ethernet, ISDN, and WLAN)
- WLAN access point
- Multi-user capability (up to 11 simultaneous sessions)
- Selectable Quality of Service (32kbps, 64kbps or 128kbps)

Package includes:

- Tracking antenna including interface box, cable set, and magnetic feet for roof mount.
 - Cable from Antenna Control Unit (ACU) box to terminal is 4 feet in length
 - Cable from ACU box to antenna is 14 feet in length*Note: These cable lengths cannot be changed due to the 7 dB attenuation required between the terminal and antenna.*
- Hughes 9250 Broadband Satellite IP Terminal and WLAN Access Point
- Vehicular install kit (includes installation hardware)
- Rechargeable lithium ion battery pack
- DC to DC power supply—powers the satellite modem as well as the tracking antenna.
- Ethernet cable
- ISDN cable
- User guide (PDF file on CD)
- Installation CD

Technical Specifications

Terminal

Weight:	2.8 Kg (terminal with battery)
Dimensions:	275 mm x 345 mm x 50 mm
Humidity:	95% RH at +40° C
Temperature:	-25° C to +60° C operating -25° C to +60° C storage (w/ battery)
Power:	Idle: 20 W Max: 100 W (when transmitting)

Antenna

Weight:	5.5 Kg
Dimensions:	Ø477 mm x 153 mm
Humidity:	95% RH at +40° C
Temperature:	-25° C to +55° C operating -25° C to +80° C survival
Wind:	125 mph (200 km/h) Exception for Magnetic Mount: 100 mph (160 km/h)
Water & Dust:	IP-56 standard
Ice:	25 mm non-operational
Vehicle Motions:	



*Global coverage is dependent upon the successful launch and operational readiness of additional Inmarsat satellite equipment. Hughes assumes no responsibility for completeness of global coverage.

**Best efforts performance under moving conditions depending on obstruction of satellite signal. Performance is limited by the BGAN system design. Signal outages of more than 3 seconds will cause circuit switched calls to be dropped and packet switched sessions will be interrupted. User intervention to reactivate connections may be required for longer outage durations

For additional information, please visit our Website at www.bgan.hughes.com.



For more information
visit www.skymira.com
or call 866.521.0540

